

SKY66427-11: Transmit/Receive RF Front-End Module for Wi-SUN® and LoRaWAN® Applications

Applications

- Supports Wi-SUN® and mesh network devices
- Internet of Things (IoT)
- Smart meters
- Industrial applications

Features

- Integrated SAW filter for out-of-band interference rejection
- North America region: 902 to 928 MHz
- Low insertion loss antenna switch paths
- RF power detector voltage output
- Integrated LNA with high IIP3 of 2.5 dBm, typical
- Integrated low pass filter for SoC harmonic suppression
- Integrated power limiter for high power interference protection
- Supply voltage: 3.0 to 5.0 V
- 20-pin, 2.8 x 2.8 x 0.765 mm LGA package (MSL3, 260 °C per JEDEC J-STD-020)
- For RoHS and other product compliance information, see the [Skyworks Certificate of Conformance](#).

Description

The SKY66427-11 is a high-performance, highly integrated RF front-end module designed for Wi-SUN and mesh network devices and applications operating in the 902 to 928 MHz frequency range.

The SKY66427-11 is designed for ease of use and maximum flexibility with fully-matched 50 Ω TX and RX inputs and antenna outputs, and digital controls.

The RF blocks operate over a supply voltage range allowing the SKY66427-11 to be used in battery powered applications over a wide spectrum of the battery discharge curve.

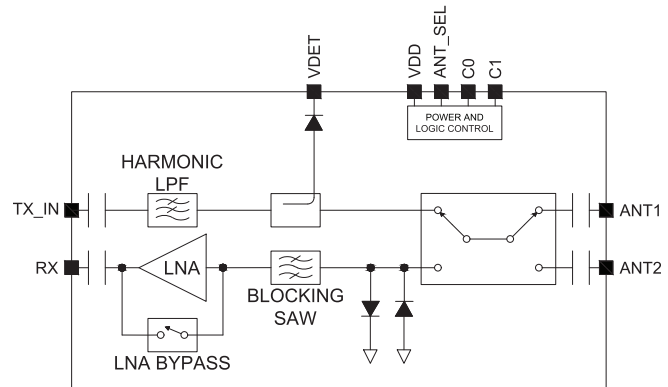

Figure 1. Functional Block Diagram

A functional block diagram of the SKY66427-11 is provided in Figure 1. Figure 2 and Table 1 shows the pinout and signal descriptions.

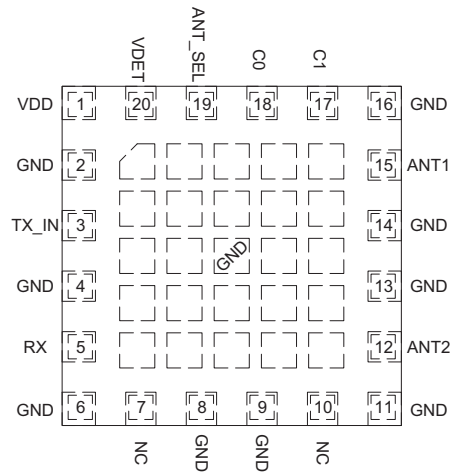

Figure 2. Pinout (Top View)

Table 1. Signal Descriptions

Pin	Name	Description
1	VDD	General voltage supply
2	GND	Ground
3	TX_IN	Transmit mode RF input
4	GND	Ground
5	RX	Receive mode RF output
6	GND	Ground
7	NC	No connect
8	GND	Ground
9	GND	Ground
10	NC	No connect
11	GND	Ground
12	ANT2	Antenna 2 RF input/output
13	GND	Ground
14	GND	Ground
15	ANT1	Antenna 1 RF input/output
16	GND	Ground
17	C1	C1 control pin
18	C0	C0 control pin
19	ANT_SEL	Antenna select control pin
20	VDET	Power detector voltage output

Technical Description

The SKY66427-11 is a transmit/receive (TRX) front-end module (FEM) supporting operation for Wi-SUN, LoRa, and other mesh network devices. An integrated, low insertion loss DPDT antenna switch enables system architectures with dual antennas.

All RF ports are internally dc-blocked, facilitating implementation. The module includes a high input IP3 LNA with a bypass feature, integrated SAW filter, and limiter for high power interference protection.

The transmit path features a low pass filter for SoC harmonic suppression.

Three digital input control pins (C0, C1, and ANT_SEL) are used to select between eight modes listed in the Control Mode Logic Table.

Electrical Specifications

The absolute maximum ratings of the SKY66427-11 are provided in Table 2. The recommended operating conditions are specified in Table 3, followed by other electrical specifications and control logic.

Table 2. Absolute Maximum Ratings¹

Parameter	Symbol	Minimum	Maximum	Units
General supply voltage (no RF)	VDD	-0.3	+5.5	V
Storage temperature	TS	-40	150	°C
TX RF input power at TX_IN port	PIN_TX_MAX		+25	dBm
RX RF input power at ANT ports	PIN_RX_MAX		+15	dBm
Control voltage absolute maximum ²	V_CTL_MAX		3.6 ²	V
Control voltage absolute minimum	V_CTL_MIN	-0.3		V

1. Exposure to maximum rating conditions for extended periods may reduce device reliability. Exceeding any of the limits listed here may result in permanent damage to the device.
2. VDD or 3.6 V, whichever is lower.

ESD Handling: Industry-standard ESD handling precautions must be adhered to at all times to avoid damage to this device.

Table 3. Recommended Operating Conditions

Parameter	Symbol	Min	Typ	Max	Units
Operating general supply voltage	VDD	3.0	3.6	5.0	V
Ambient temperature	TA	-40	25	85	°C
Voltage control level high	VIH	1.5		VDD	V
Voltage control level low	VIL	0		0.5	V

Table 4. DC¹

(VDD = 3.6 V, f = 902 to 928 MHz, TA = +25 °C, Unless Otherwise Noted)

Parameter	Symbol	Min	Typ	Max	Units
RX current consumption, LNA active	RX_ACTIVE_IDD		6		mA
RX current consumption, LNA bypass	RX_LNA_BYP_IDD		45		μA
TX quiescent current consumption	TX_IDQ		1.5		mA
TX current consumption	TX_IDD		2		mA
Sleep current consumption	SLEEP_IDD		0.5	1	μA

1. Performance is assured only under the conditions listed in this table. Operation at elevated temperatures may reduce reliability of the device.

Table 5. RF Coupler and Detector Voltage Output¹

(VDD = 3.6 V, f = 902 to 928 MHz, TA = +25 °C, Unless Otherwise Noted)

Parameter	Symbol	Conditions	Min	Typ	Max	Units
VDET power detector voltage output	VDET_VOUT	f = 915 MHz P_OUT = 0 dBm P_OUT = +20 dBm		0.4 2.4		V
VDET output impedance	VDET_OUT_IMPEDANCE			1200		Ω

1. Performance is assured only under the conditions listed in this table. Operation at elevated temperatures may reduce reliability of the device.

Table 6. RX¹

(VDD = 3.6 V, f = 902 to 928 MHz, TA = +25 °C, Unless Otherwise Noted)

Parameter	Symbol	Conditions	Min	Typ	Max	Units
Input compression point	IP1dB_BP_ANT1_RX IP1dB_BP_ANT2_RX	LNA bypass: ANT1 to RX LNA bypass: ANT2 to RX	8	11		dBm
Noise figure	LNA_NF_ANT1_RX LNA_NF_ANT2_RX	LNA active: ANT1 to RX LNA active: ANT2 to RX		3		dB
Input compression point	LNA_IP1dB_ANT1 LNA_IP1dB_ANT2	LNA active: ANT1 to RX LNA active: ANT2 to RX	-10.5	-8		dBm
IIP3	LNA_IIP3_ANT1 LNA_IIP3_ANT2	LNA active: ANT1 to RX LNA active: ANT2 to RX	0	2.5		dBm
Input return loss	RL_ANT1 RL_ANT2	LNA active: ANT1 to RX LNA active: ANT2 to RX		12		dB
Output return loss	RL_RX	LNA active: ANT1 to RX LNA active: ANT2 to RX		16		dB
Small signal gain	LNA_GAIN_ANT1 LNA_GAIN_ANT2	LNA active: ANT1 to RX LNA active: ANT2 to RX		14.5		dB

1. Performance is assured only under the conditions listed in this table. Operation at elevated temperatures may reduce reliability of the device.

Table 7. TX Filter (TX Mode) and SAW Filter (LNA Bypass Mode)¹
 (VDD = 3.6 V, f = 902 to 928 MHz, TA = +25 °C, Unless Otherwise Noted)

Parameter	Symbol	Conditions	Min	Typ	Max	Units
RX filter rejection	FILT_REJ	RX: 10 to 824 MHz		48		dB
		RX: 824 to 890 MHz		41		
		RX: 890 to 894 MHz		34		
		RX: 941 to 960 MHz		44		
		RX: 960 to 1350 MHz		51		
		RX: 1350 to 2000 MHz		54		
		RX: 2000 to 3000 MHz		57		
		RX: 3000 to 6000 MHz		36		
RX insertion loss	FILT_IL	RX: ANT1/ANT2 to RX		3		dB
RX in-band ripple	IBR_SAW_ANT1/2	RX: ANT1/ANT2 to RX over 1 MHz window		0.4	1	dBpp
TX in-band ripple	TX_ANT1_LPF_IBR TX_ANT2_LPF_IBR	TX		0.1		dBpp
TX filter rejection	TX_ANT1_LPF_REJ_H2 TX_ANT2_LPF_REJ_H2	TX: 1804 MHz		40		dB
	TX_ANT1_LPF_REJ_H3 TX_ANT2_LPF_REJ_H3	TX: 2706 to 2784 MHz		36		

1. Performance is assured only under the conditions listed in this table. Operation at elevated temperatures may reduce reliability of the device.

Table 8. TX/RX/ANT¹
 (VDD = 3.6 V, f = 902 to 928 MHz, TA = +25 °C, Unless Otherwise Noted)

Parameter	Symbol	Conditions	Min	Typ	Max	Units
Insertion loss	IL_TX_ANT1 IL_TX_ANT2	TX: TX_IN to ANT1 TX: TX_IN to ANT2		1.25		dB
Insertion loss	IL_RX_ANT1 IL_RX_ANT2	LNA bypass: ANT1 to RX LNA bypass: ANT2 to RX		3		dB
Isolation	ISO_ANT1_ANT2	RX: ANT1 to ANT2		25		dB
Isolation	ISO_TX_RX	TX: TX_IN to RX		50		dB
Return loss	RL_TX_IN_ANT1 RL_TX_IN_ANT2	TX to ANT1: TX_IN return loss TX to ANT2: TX_IN return loss		20		dB
Return loss	RL_ANT1_TX_IN RL_ANT2_TX_IN	TX to ANT1: ANT1 return loss TX to ANT2: ANT2 return loss		20		dB
Return loss	RL_RX_ANT1 RL_RX_ANT2	LNA bypass to ANT1: RX return loss LNA bypass to ANT2: RX return loss		10		dB
Return loss	RL_ANT1_RX RL_ANT2_RX	LNA bypass to ANT1: ANT1 return loss LNA bypass to ANT2: ANT2 return loss		10		dB
Compression point	IP0.1dB_TX_ANT1 IP0.1dB_TX_ANT2	TX to ANT1 0.1dB compression point f = 915 MHz TX to ANT2 0.1dB compression point f = 915 MHz		25		dBm

1. Performance is assured only under the conditions listed in this table. Operation at elevated temperatures may reduce reliability of the device.

Table 9. Timing¹

(VDD = 3.6 V, f = 902 to 928 MHz, TA = +25 °C, Unless Otherwise Noted)

Parameter	Symbol	Conditions	Min	Typ	Max	Units
Wake-up time	T_ON_TX	SLEEP to TX		2		μs
Wake-up time	T_ON_RX T_ON_RX_BYP	SLEEP to RX SLEEP to RX bypass		4		μs
RX mode switching time	T_RX_RX_BYP T_RX_BYP_RX	RX to RX bypass RX bypass to RX		1		μs
TX/RX switching time	T_RX_TX T_TX_RX	RX to TX TX to RX		1		μs
Antenna switching time	T_SW	ANT1 to ANT2 ANT2 to ANT1		1		μs

1. Performance is assured only under the conditions listed in this Table.

Table 10. Mode Control Logic

Mode	ANT_SEL	C0	C1
Sleep	0	0	0
TX_IN to ANT1	0	0	1
ANT1 to RX LNA bypass	0	1	0
ANT1 to RX LNA active	0	1	1
Reserved	1	0	0
TX to ANT2	1	0	1
ANT2 to RX LNA bypass	1	1	0
ANT2 to RX LNA active	1	1	1

Evaluation Board

The SKY66427-11-EK1 evaluation board is designed to demonstrate the performance of the SKY66427-11.

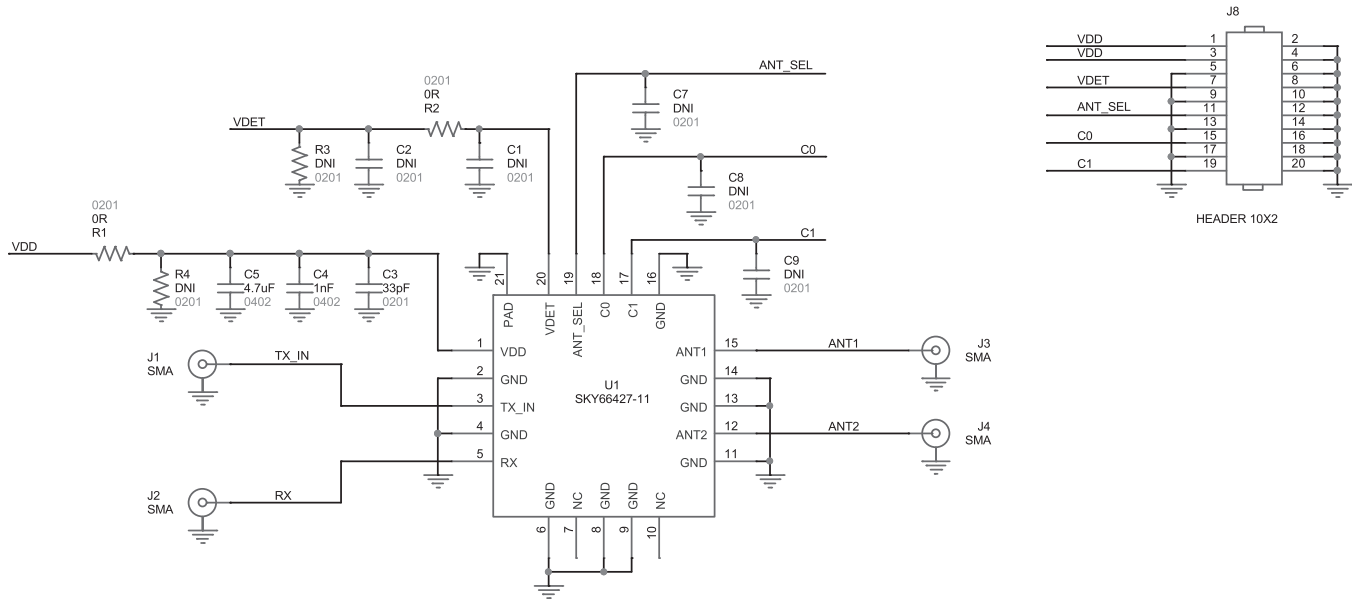

Figure 3. Evaluation Board Schematic

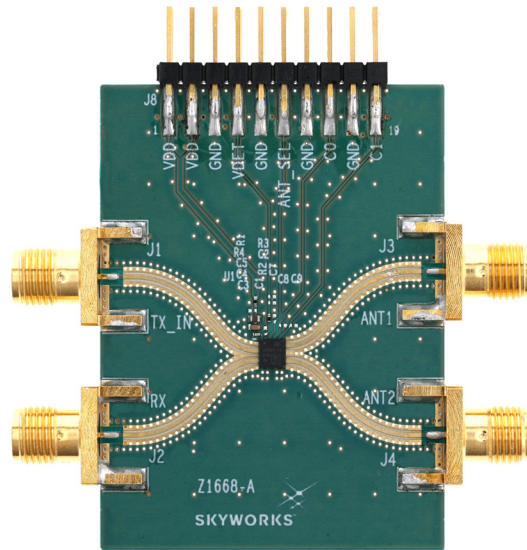

Figure 4. Evaluation Board

Table 11. Evaluation Board Bill of Materials

Reference	Quantity	Value	Manufacturer	Part Number	Package	Description
C1, C2, R3, R4, C7, C8, C9	7	DNI				
C3	1	33 pF	Murata	GRM0335C1H330JA01	0201	Capacitor, ceramic, 50 V, COG/NPO
C4	1	1 nF	Murata	GRM155R71H102KA01	0402	Capacitor, ceramic, 50 V, X7R
C5	1	4.7 μ F	Murata	GRM155R61A475MEAAD	0402	Capacitor, ceramic, 10 V, X5R
J1, J2, J3, J4	4	SMA	SPC/Multicomp	R19-070-18-0032210MM	SMA	SMA, end-launch
J8	1	Header, 10 x 2	Samtec	TSW-110-07-G-D	100mil	Header 10 x 2 100 mil
PCB1	1	Z1668-A	Skyworks Solutions Inc.	Z1668-A	1500	Printed circuit board
R1, R2	2	0 Ω	Panasonic	ERJ-1GN0R00C	0201	Resistor, 0 Ω jumper, 1/20 W
U1	1	SKY66427-11	Skyworks Solutions Inc.	SKY66427-11	2.8 x 2.8	Transmit/receive rf front-end module

PCB Recommendations

1. Bottom layer: Minimize or eliminate traces on the bottom.
2. Avoid using thermal relief pads for component ground connections and the shield case. Always place vias close to each shunt connection.
3. Spread ground vias equally to stitch the grounds together.
4. Metal layer 1: RF traces (microstrip or co-planar waveguide) and control lines. Core thickness between top RF layer and ground plane is critical.
5. Metal layer 2: Solid ground plane. No trace routings.
6. Metal layer 3: Control lines and VCC traces. No VCC plane.
7. Metal layer 4: Solid ground plane under the shield case area.
8. Pour copper on each layer connected to the ground plane.

Package and Handling Information

Since the device is sensitive to moisture absorption, it is baked and vacuum packed before shipping. Instructions on the shipping container label regarding exposure to moisture after the container seal is broken must be followed. Otherwise, problems related to moisture absorption may occur when the part is subjected to high temperature during solder assembly. The SKY66427-11 is rated to Moisture Sensitivity Level 3 (MSL3) at 260 °C. It can be used for lead- or lead-free soldering. For additional information, refer to the Skyworks Application Note, "Solder Reflow Information," document number 200164.

Care must be taken when attaching this product, whether it is done manually or in a production solder reflow environment. Production quantities of this product are shipped in a standard tape and reel format.

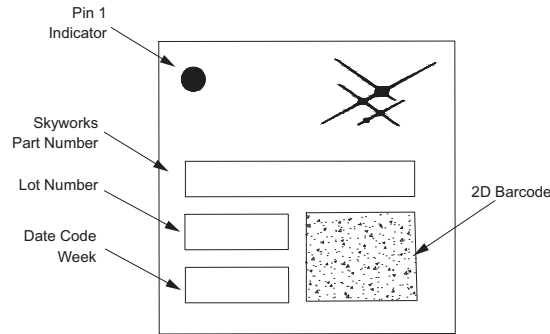
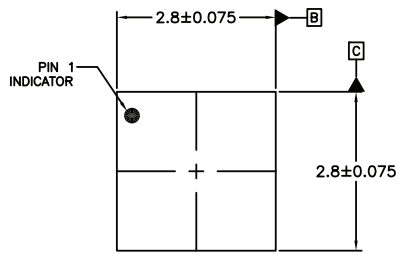
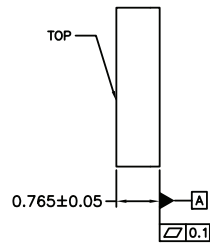

Figure 5. Typical Part Marking



TOP VIEW



SIDE VIEW

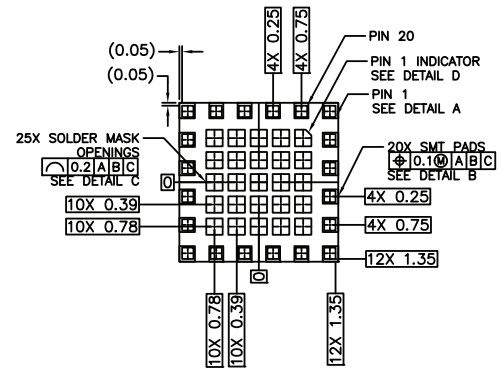

BOTTOM VIEW

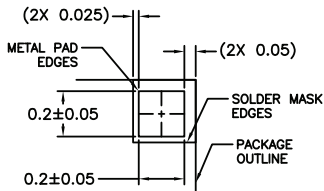

DETAIL A

PAD
SCALE: 4X
1X THIS ROTATION
1X ROTATED 180°
1X ROTATED 90° CW
1X ROTATED 90° CCW

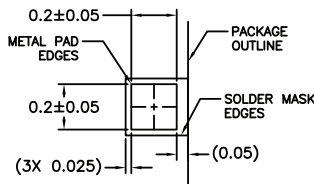

DETAIL B

PAD
SCALE: 4X
4X THIS ROTATION
4X ROTATED 180°
4X ROTATED 90° CW
4X ROTATED 90° CCW

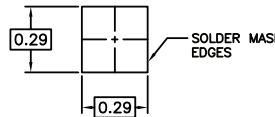

DETAIL C

PAD
SCALE: 4X
24X THIS ROTATION

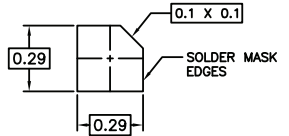

DETAIL D

PAD
SCALE: 4X
1X THIS ROTATION

NOTES: UNLESS OTHERWISE SPECIFIED.

1. DIMENSIONING AND TOLERANCING IN ACCORDANCE WITH ASME Y14.5M-1994.
2. DIMENSIONS ARE IN MILLIMETERS
3. PAD DEFINITIONS PER DETAILS ON DRAWING.

Figure 6. Package Dimensions

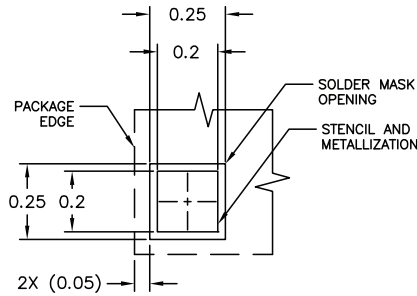
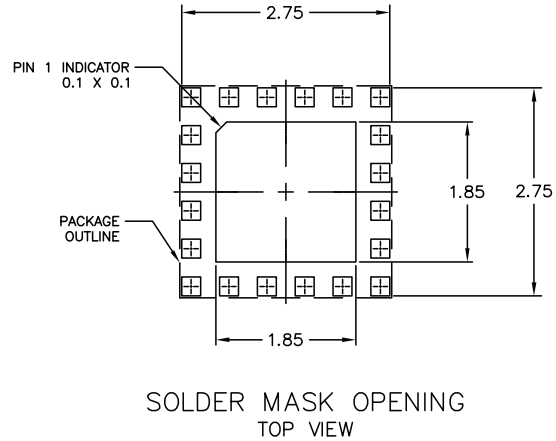
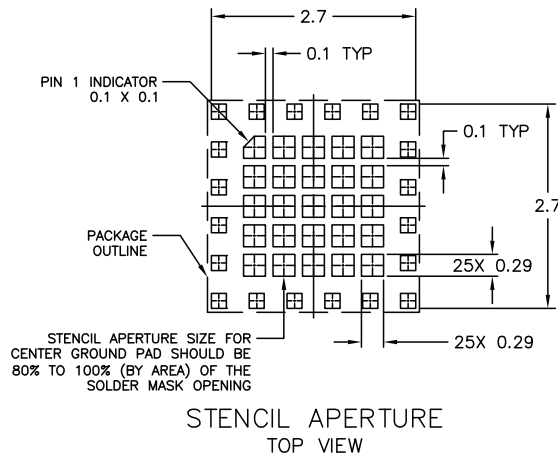

1X THIS ROTATION
1X ROTATED 180°
1X ROTATED 90°CW
1X ROTATED 90°CCW

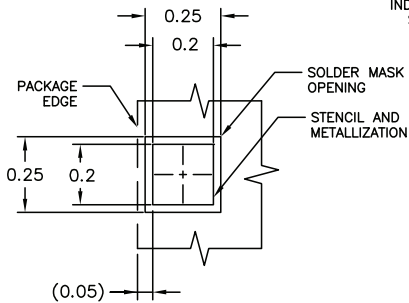

4X THIS ROTATION
4X ROTATED 180°
4X ROTATED 90°CW
4X ROTATED 90°CCW

NOTES:

1. DIMENSIONS ARE IN MILLIMETERS, UNLESS OTHERWISE SPECIFIED.
2. THERMAL VIAS SHOULD BE RESIN FILLED AND CAPPED IN ACCORDANCE WITH IPC-4761 TYPE VII VIAS. 30-35UM Cu THICKNESS IS RECOMMENDED.

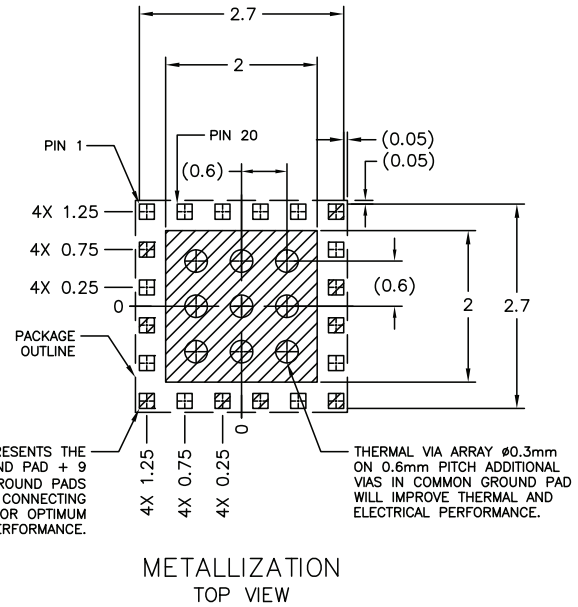

THE CROSSHATCHED AREA REPRESENTS THE MERGER OF THE CENTER GROUND PAD + 9 INDIVIDUAL I/O GROUND. ALL I/O GROUND PADS SHOULD HAVE AT LEAST ONE VIA CONNECTING TO INTERNAL GROUND PLANES FOR OPTIMUM ELECTRICAL PERFORMANCE.

THERMAL VIA ARRAY Ø0.3mm ON 0.6mm PITCH ADDITIONAL VIAS IN COMMON GROUND PAD WILL IMPROVE THERMAL AND ELECTRICAL PERFORMANCE.

Figure 7. PCB Layout Footprint

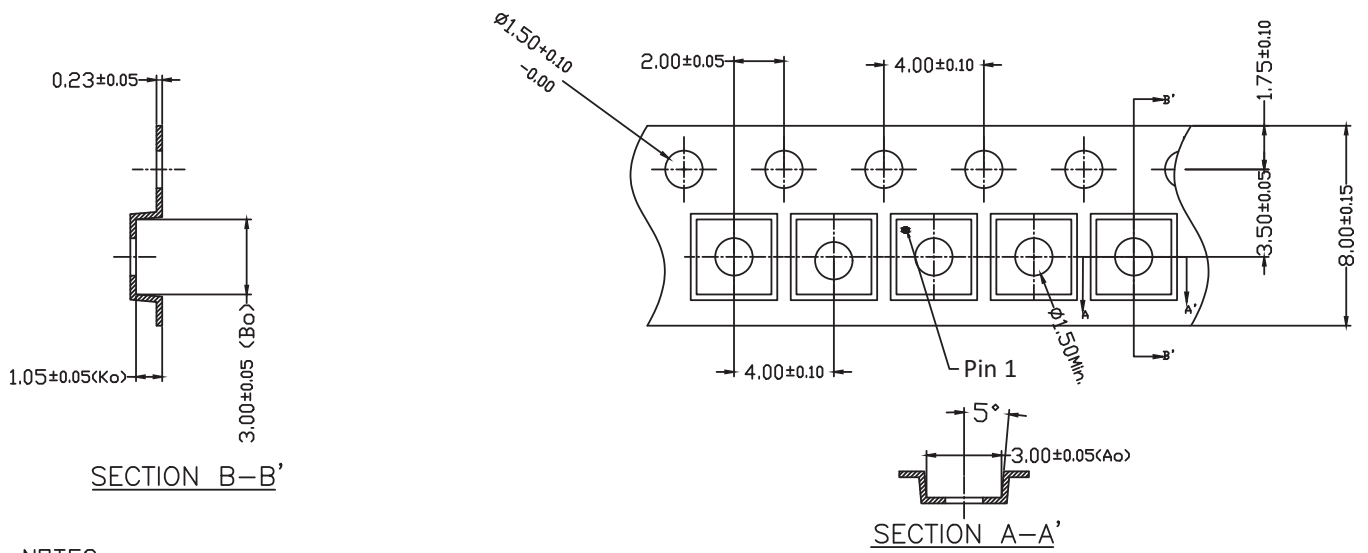

NOTES:

- 10 SPROCKET HOLE PITCH CUMULATIVE TOLERANCE : ± 0.20 mm
- Ao & Bo MEASURED ON PLANE 0.30mm ABOVE THE BOTTOM OF THE POCKET.
- ALL DIMENSIONS ARE IN MILLIMETERS.

Figure 8. Tape and Reel Information

Ordering Information

Part Number	Description	Evaluation Board Part Number
SKY66427-11	Transmit/Receive RF Front-End Module for Wi-SUN® and LoRaWAN® Applications	SKY66427-11EK1

Copyright © 2024-2026, Skyworks Solutions, Inc. All Rights Reserved.

Information in this document is provided in connection with Skyworks Solutions, Inc., and its subsidiaries (“Skyworks”) products or services. These materials, including the information contained herein, are provided by Skyworks as a service to its customers and may be used for informational purposes only by the customer. Skyworks assumes no responsibility for errors or omissions in these materials or the information contained herein. Skyworks may change its documentation, products, services, specifications or product descriptions at any time, without notice. Skyworks makes no commitment to update the materials or information and shall have no responsibility whatsoever for conflicts, incompatibilities, or other difficulties arising from any future changes.

No license, whether express, implied, by estoppel or otherwise, is granted to any intellectual property rights by this document. Skyworks assumes no liability for any materials, products or information provided hereunder, including the sale, distribution, reproduction or use of Skyworks products, information or materials, except as may be provided in Skyworks’ Terms and Conditions of Sale.

THE INFORMATION IN THIS DOCUMENT AND THE MATERIALS AND PRODUCTS DESCRIBED THEREIN ARE PROVIDED “AS IS” WITHOUT WARRANTY OF ANY KIND, WHETHER EXPRESS, IMPLIED, STATUTORY, OR OTHERWISE, INCLUDING FITNESS FOR A PARTICULAR PURPOSE OR USE, MERCHANTABILITY, PERFORMANCE, QUALITY OR NON-INFRINGEMENT OF ANY INTELLECTUAL PROPERTY RIGHT; ALL SUCH WARRANTIES ARE HEREBY EXPRESSLY DISCLAIMED. SKYWORKS DOES NOT WARRANT THE ACCURACY OR COMPLETENESS OF THE INFORMATION, TEXT, GRAPHICS OR OTHER ITEMS CONTAINED WITHIN THESE MATERIALS. SKYWORKS SHALL NOT BE LIABLE FOR ANY DAMAGES, INCLUDING BUT NOT LIMITED TO ANY SPECIAL, INDIRECT, INCIDENTAL, STATUTORY, OR CONSEQUENTIAL DAMAGES, INCLUDING WITHOUT LIMITATION, LOST REVENUES OR LOST PROFITS THAT MAY RESULT FROM THE USE OF THE MATERIALS OR INFORMATION, WHETHER OR NOT THE RECIPIENT OF MATERIALS HAS BEEN ADVISED OF THE POSSIBILITY OF SUCH DAMAGE.

Skyworks products are not designed, intended, authorized, or warranted for use or inclusion in life support or life endangering applications, devices, or systems where failure or inaccuracy might cause death or personal injury. Skyworks customers agree not to use or sell the Skyworks products for such applications, and further agree to, without limitation, fully defend, indemnify, and hold harmless Skyworks and its agents from and against any and all actions, suits, proceedings, costs, expenses, damages, and liabilities including attorneys’ fees arising out of or in connection with such improper use or sale.

Skyworks assumes no liability for applications assistance, customer product design, or damage to any equipment resulting from the use of Skyworks products outside of Skyworks’ published specifications or parameters. Customers are solely responsible for their products and applications using the Skyworks products.

“Skyworks” and the Skyworks Starburst logo are registered trademarks of Skyworks Solutions, Inc., in the United States and other countries. Third-party brands and names are for identification purposes only and are the property of their respective owners. Additional information, including relevant terms and conditions, posted at www.skyworksin.com, are incorporated by reference.